

# “Setpoints”

**Don Eppelheimer**  
**The Trane Company**  
**La Crosse, Wisconsin**

# Earthwise is..

- ♦ **supply air less than 50 F**
- ♦ **chilled water less than 40 F**
- ♦ **water to tower greater than 100 F**
- ♦ **integrated control**

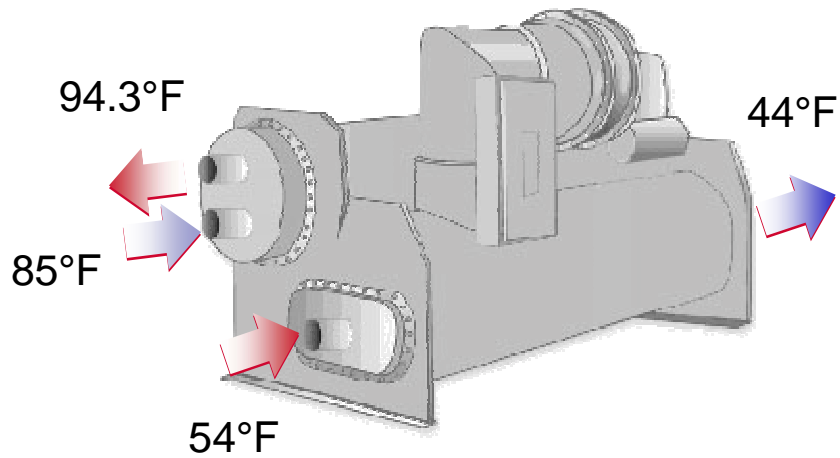

## ARI conditions

evaporator flow rate	2.4 gpm/ton
condenser flow rate	3.0 gpm/ton

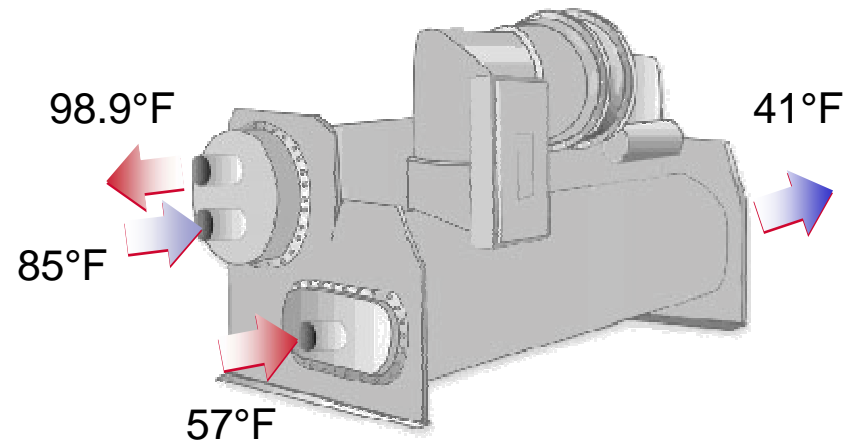

## Applied conditions

evaporator flow rate	1.5 gpm/ton
condenser flow rate	2.0 gpm/ton

# Cooling Coil Performance

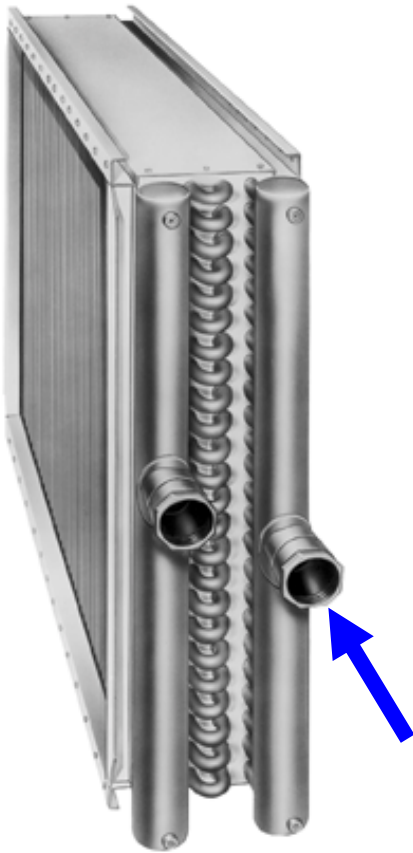

TMBH	476.5	475.6
<b>EWT</b>	<b>44 F</b>	<b>41 F</b>
WTR	<b>10 F</b>	<b>15.1 F</b>
GPM	95.3	63.0

# Chilled Water System

2000 cooling tons  
Jackson Mississippi



Tower CT-01 Enabled  
Tower CT-02 Disabled

CW Supply 75  
CW Return 98

Chiller-01 Enabled  
Chiller-02 Disabled

CHWS Temp 49.0F

CHW Supply 50.9  
CHW Return 61.4

CTP-01 Status: On  
CTP-02 Status: On

CWP-01 Status: On  
CWP-02 Status: Off

44°F



# Annual Energy Consumption

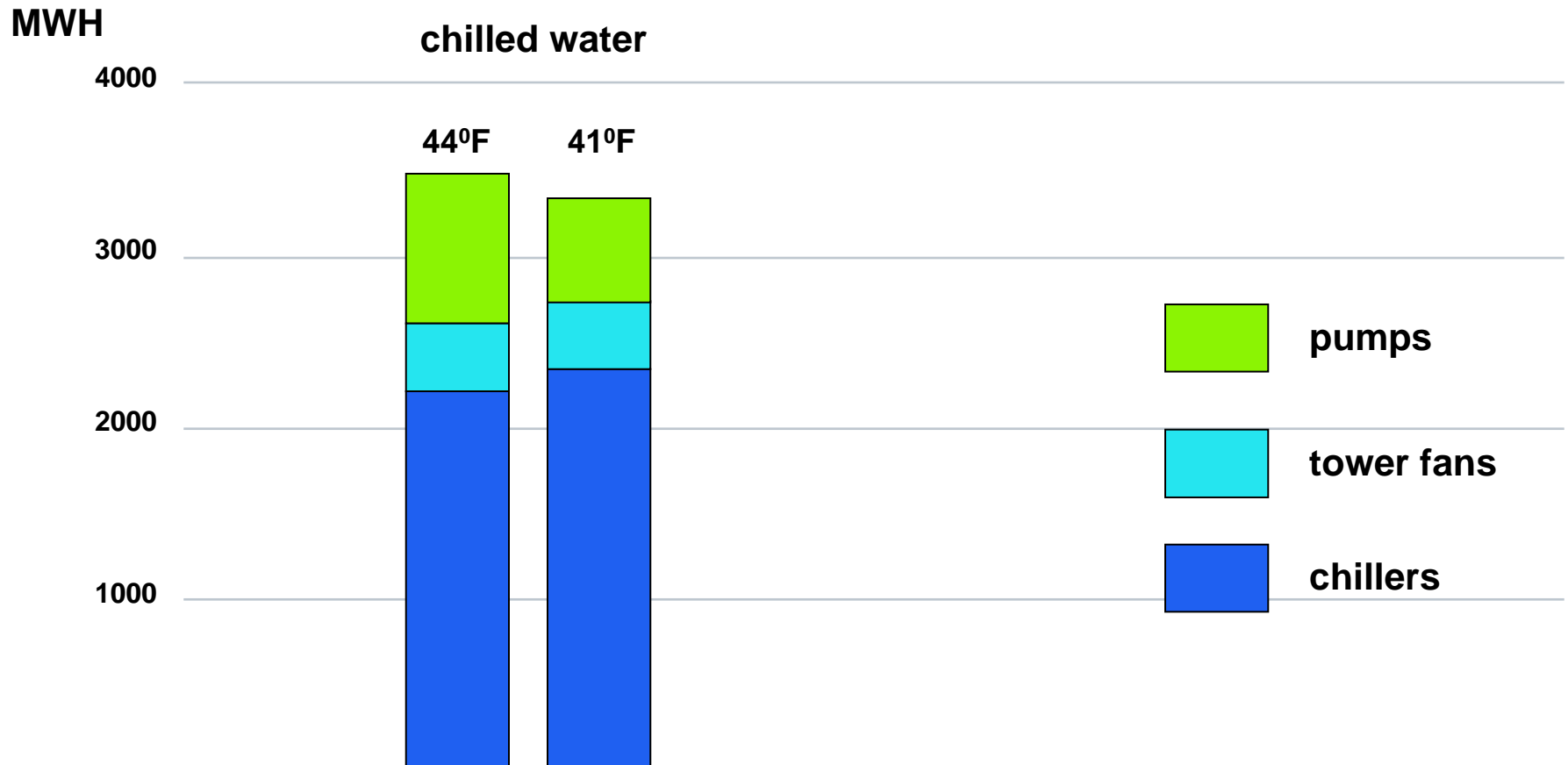

2000 ton chilled water system

# Cooling Tower Capital Cost

6000 gpm

4 cells  
120 hp  
17 x 36 ft  
58,800 lbs

## 2000 ton chilled water system

# Cooling Tower Capital Cost

6000 gpm

4 cells  
120 hp  
17 x 36 ft  
58,800 lbs

4000  
gpm

2 cells  
80 hp  
20 x 24 ft  
44,500 lbs

3000 gpm

1 cell  
50 hp  
12 x 22 ft  
36,600 lbs

# Cooling Tower Capital Cost

- ♦ **Cooling tower capital cost is not a function of chiller capacity**
- ♦ **Cooling towers are sized by the amount of water they process**

2000 ton chilled water system

# Cooling Tower Energy Cost

6000 gpm

120 hp

95/85/78

4000 gpm

80 hp

100/85/78

3000 gpm

60 hp

105/85/78

# Annual Energy Consumption

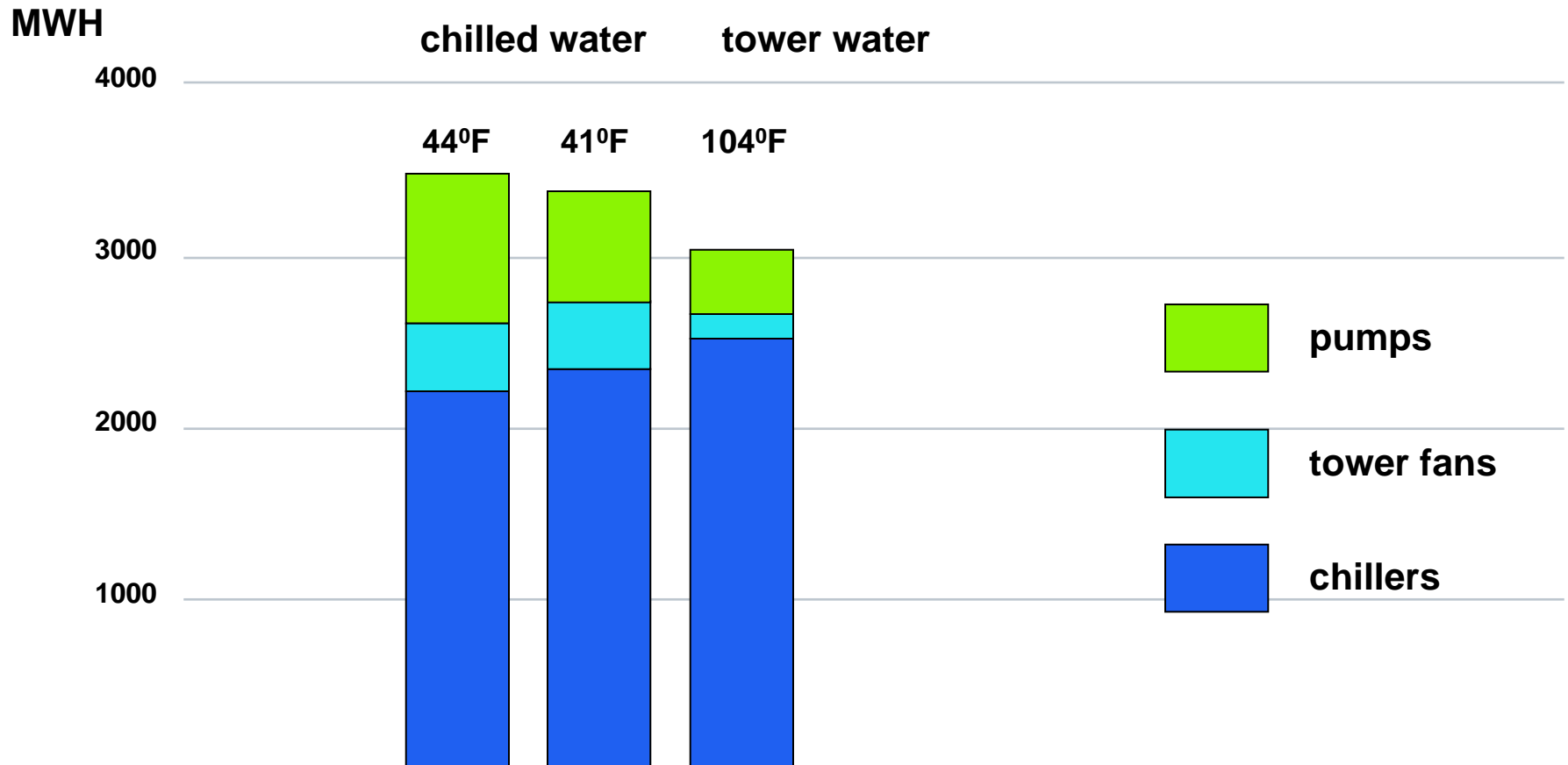

# Annual Energy Consumption

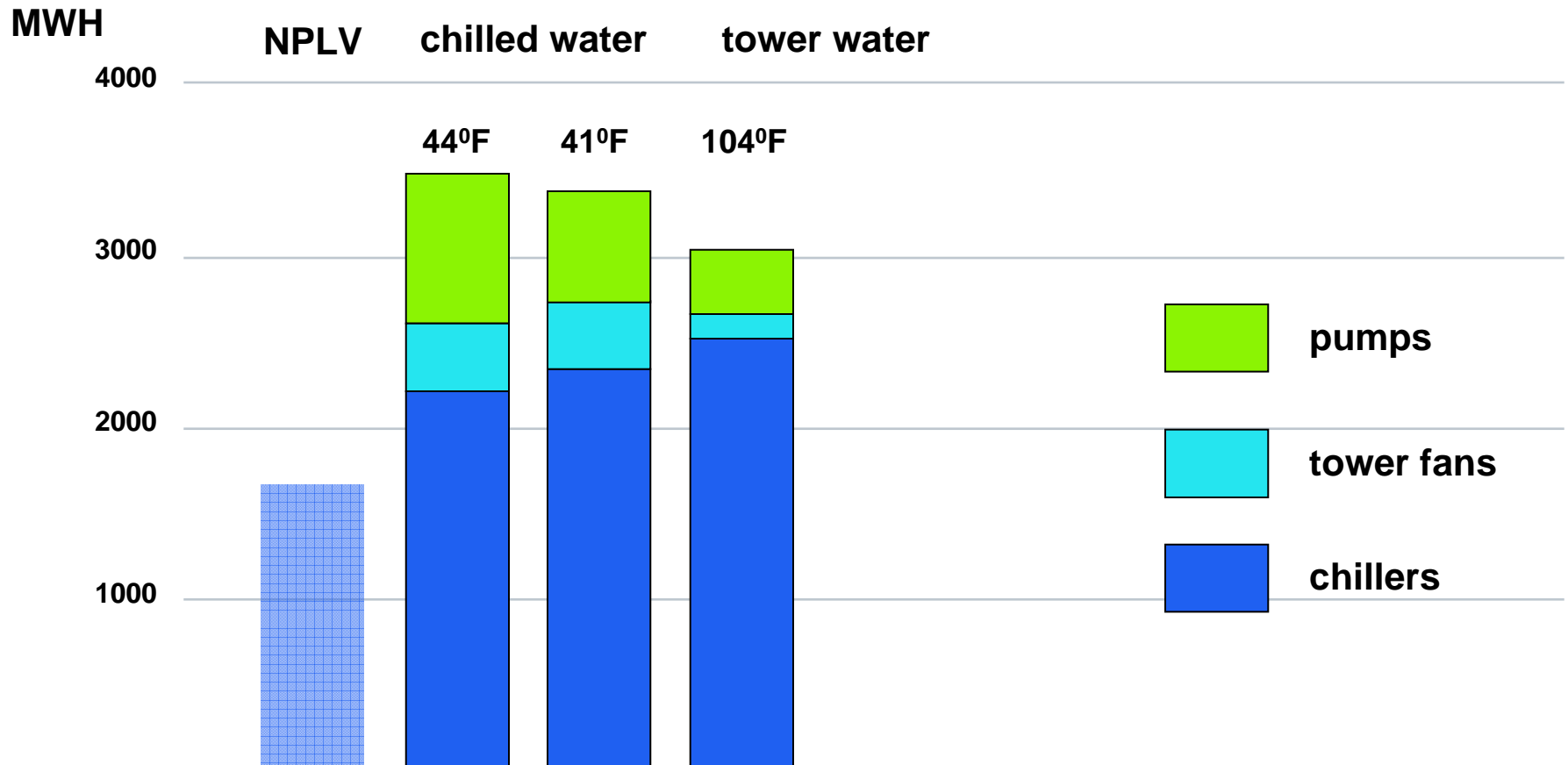

# Compressor Work

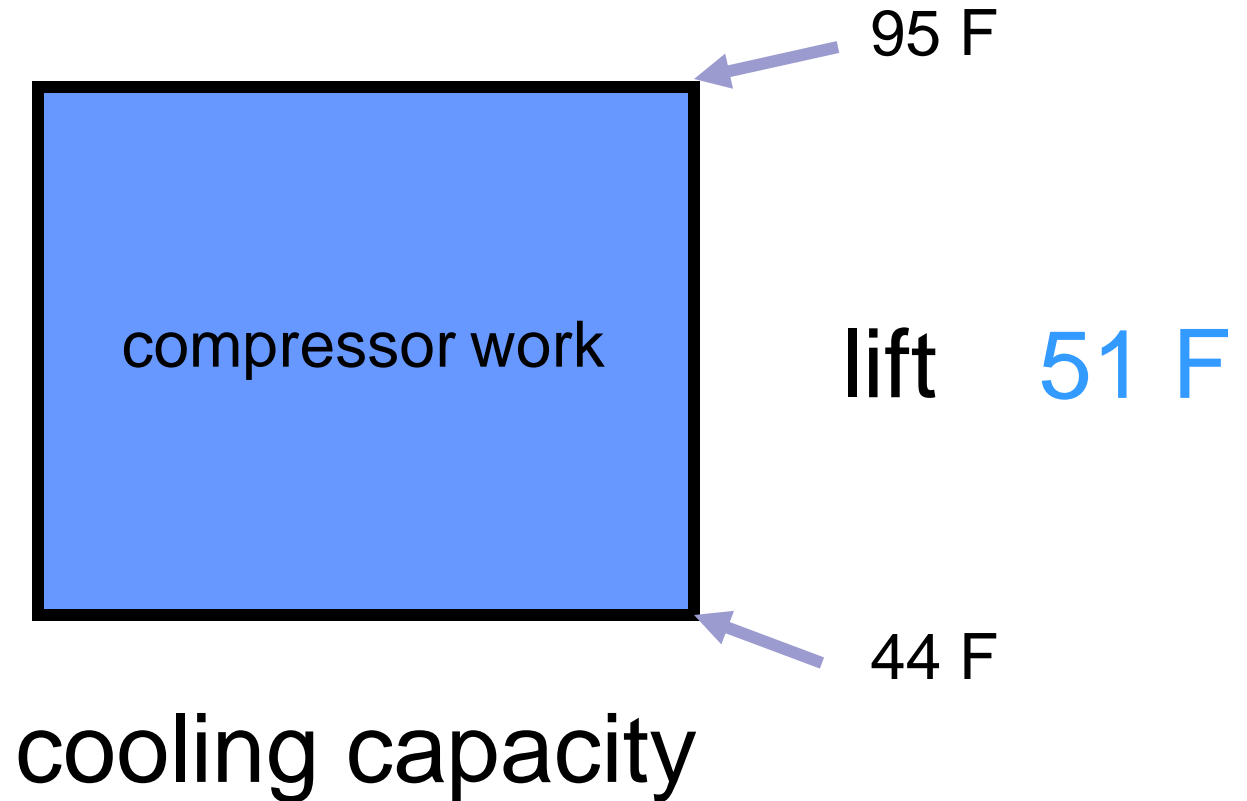

# Compressor Work

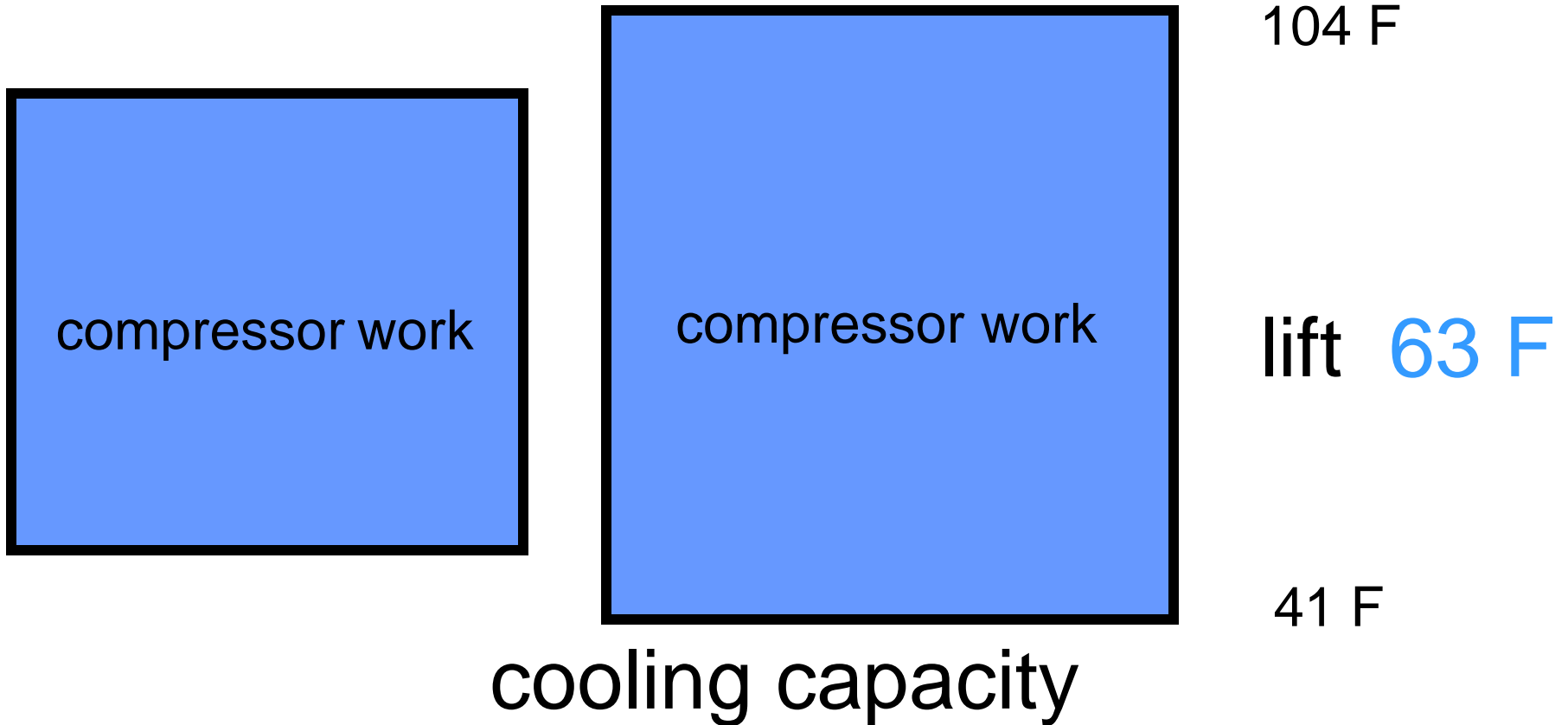

# Annual Energy Consumption

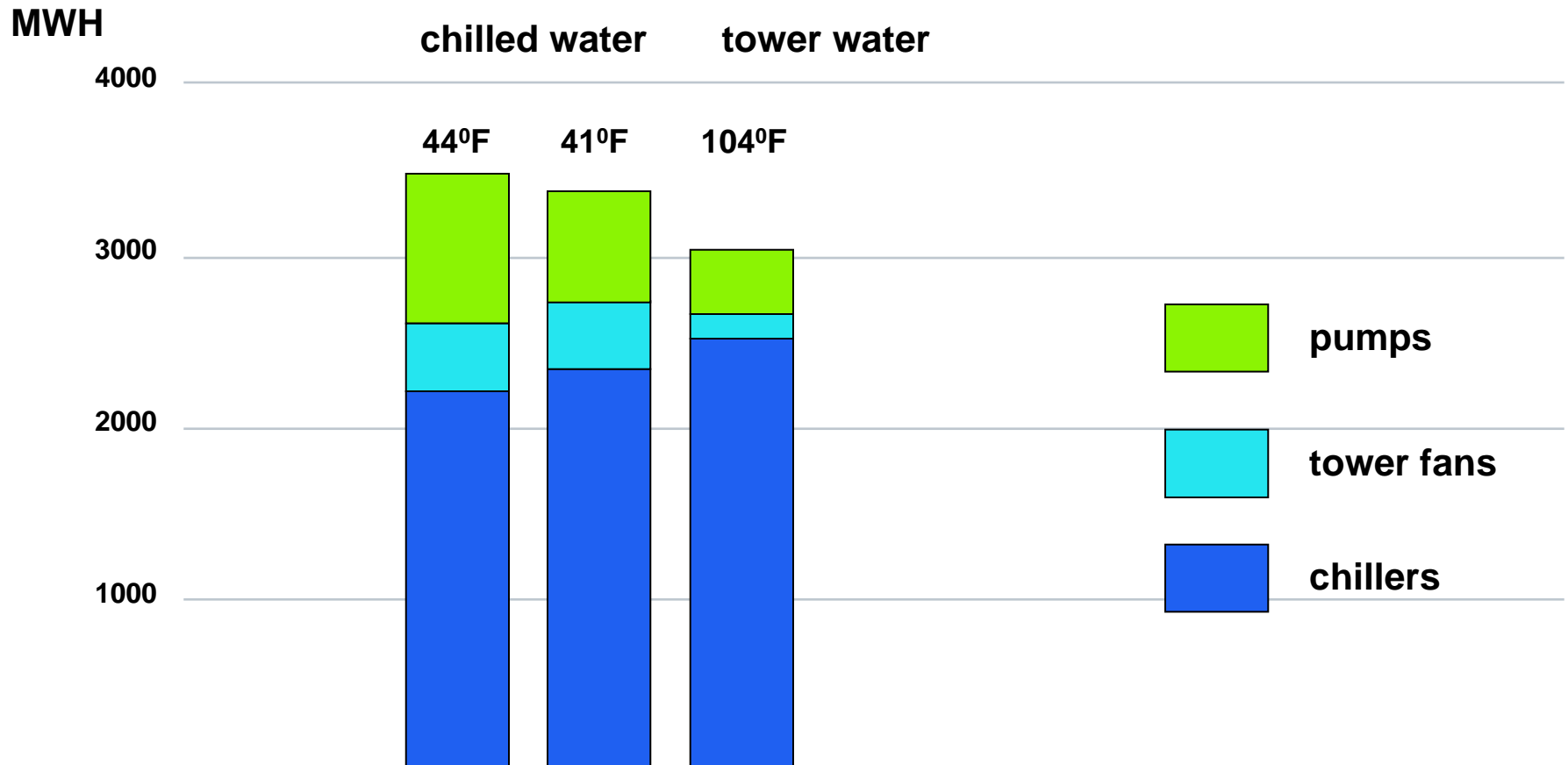

# Series Counterflow

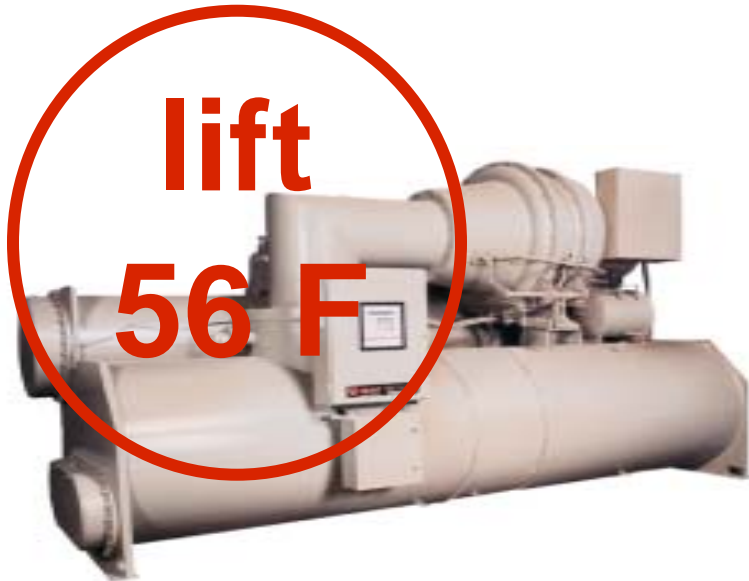

**lift**  
**56 F**

**104**



**57**



**lift**  
**53 F**

**94**



**85**

**48**



**41**

# Compressor Work

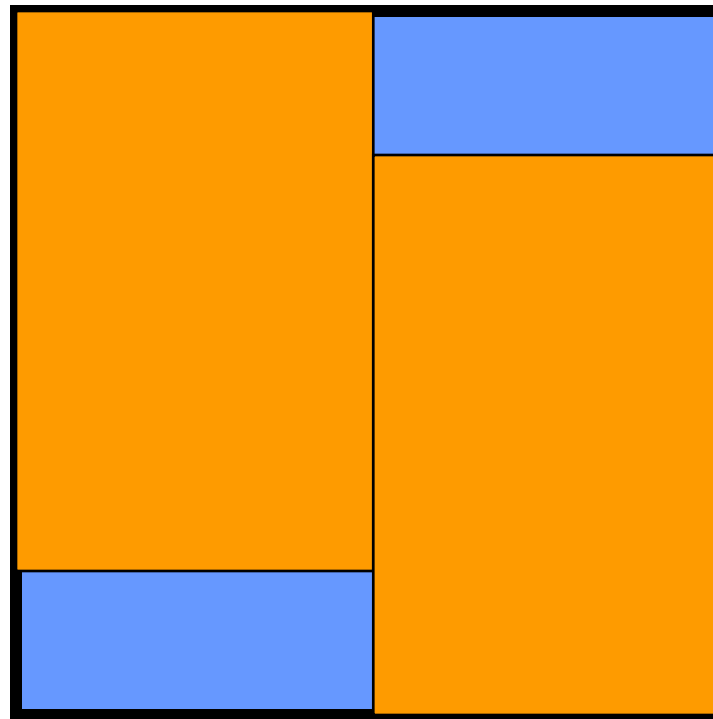

104 F

lift ~54 F

41 F

cooling capacity

# Annual Energy Consumption

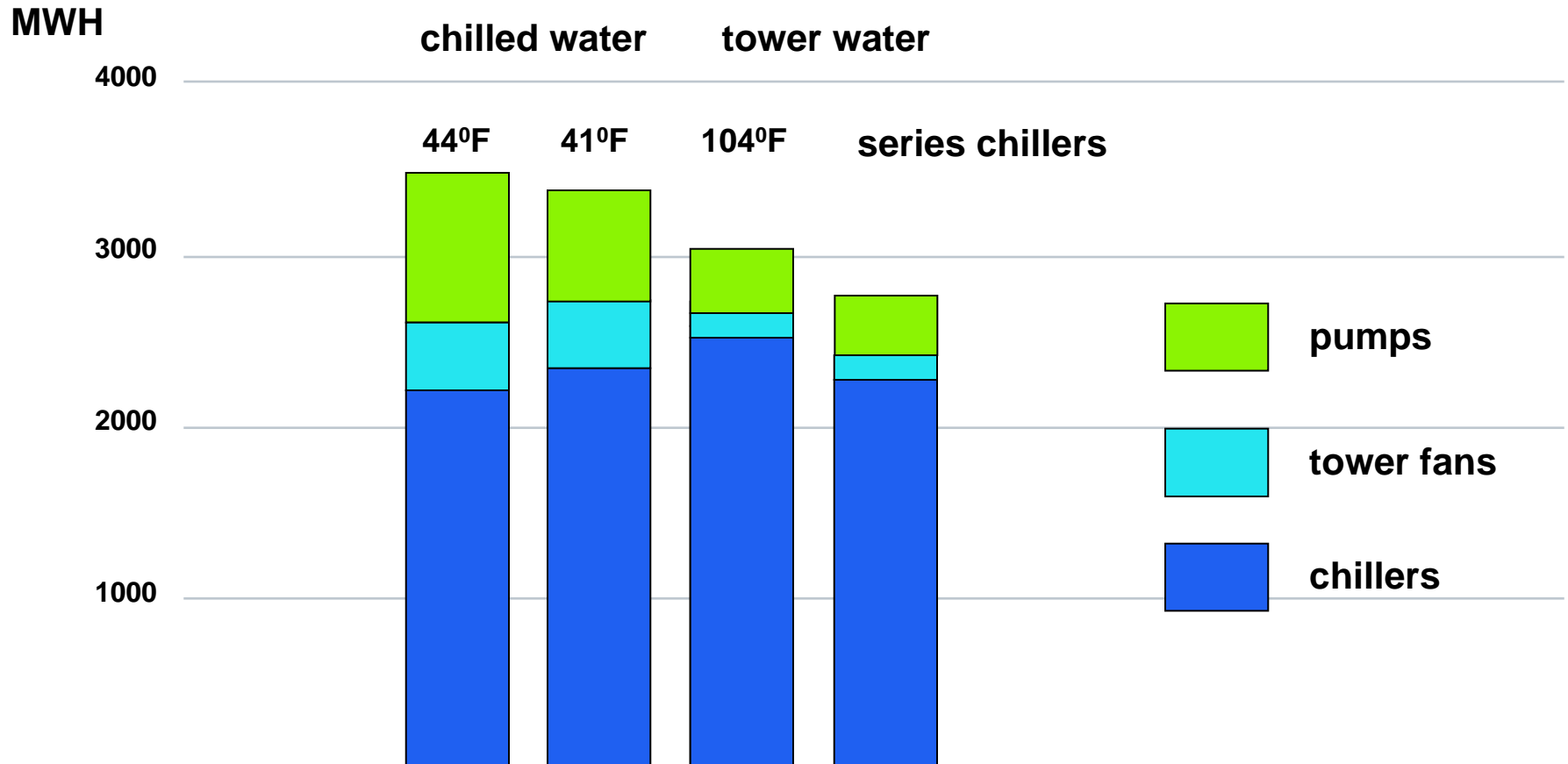

# Cooling Tower Water Consumption

- ♦ **Chilled water pump power is rejected to atmosphere by the cooling tower**
- ♦ **Compressor power is rejected to atmosphere by the cooling tower**
- ♦ **Condenser water pump power is rejected to atmosphere by the cooling tower**

# Cooling Tower Water Savings

2000 ton Chilled Water System

**Colder Chilled Water**                      **149,100**    **gallons**

**Warmer Tower Water**                      **83,350**

**Series Chillers**                              **350,900**

---

**Earthwise Total**                              **583,350**    **gallons**

**2,290 cubic meters annually**

# Earthwise Systems

- ◆ **Colder chilled water saves energy**
  - ◆ Chilled water pumps
- ◆ **Warmer cooling tower water saves energy**
  - ◆ Condenser water pumps
  - ◆ Cooling tower fans
- ◆ **Series chillers**
  - ◆ Compressors
- ◆ **Earthwise saves water**
  - ◆ Chilled water and condenser water pumps
  - ◆ Series chillers

**Cold Air**

**“move less air”**

# What is the difference?

**Current practice**

**Cold air distribution**

**supply air**

**55 F**

**45 F**

**room setpoint**

**75 F**

**78 F**

**delta t**

**20 F**

**33 F**

**cfm/ton sensible**

**550**

**335**

# Cold Air Benefits

**\$ Lower Equipment Cost**

**\$ Lower Building Cost**

**\$ Lower Energy Cost**

**\$ Better Indoor Air Quality and Comfort**

# Cold Air Benefits

## **\$** Lower Equipment Cost

<b>ductwork</b>	<b>10-15%</b>
<b>air handlers</b>	<b>20-30%</b>
<b>coils</b>	<b>no change</b>
<b>chillers</b>	<b>no change</b>
<b>terminal units</b>	<b>2-3%</b>

# Finding The Right Air Handler

<b>Supply Air</b>	<b>CFM</b>	<b>Coil Area</b>	<b>Fan Discharge Velocity</b>	<b>Coil Face Velocity</b>	<b>Fan hp</b>
<b>55 F</b>	<b>18,750</b>	<b>34.1</b>	<b>2514</b>	<b>550</b>	<b>17.8</b>
<b>45</b>	<b>11,360</b>	<b>20.8</b>	<b>2225</b>	<b>546</b>	<b>12.8</b>
<b>45</b>	<b>11,360</b>	<b>24.4</b>	<b>1803</b>	<b>466</b>	<b>9.6</b>

# Fan Room Floor Area



# Fan Room Floor Area

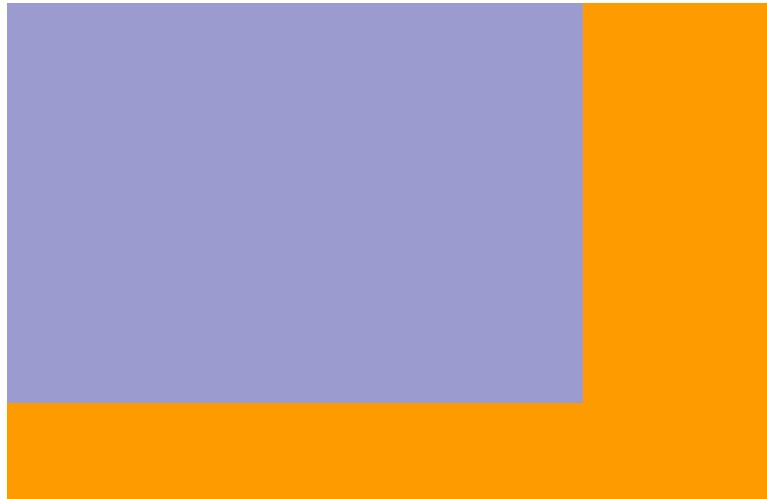

# Fan Room Floor Area



# Cold Air Benefits

## **\$ Lower Building Cost**

**smaller fan rooms**

**smaller duct transitions**

**less sound attenuation**

**lower floor to floor height**

# Cold Air Benefits

## **\$ Lower Energy Cost**

**less fan horsepower**

**less pump horsepower**

**chiller and tower ?**

more latent load

less fan heat load

# Cold Air Benefits

## **\$ Better Indoor Air Quality**

**lower humidity**

**less microbial growth**

**less property damage**

**higher comfort level**

## Before Lighting Retrofit

Lights  
watts/ft<sup>2</sup>

Air Side  
cfm

Latent  
lbs/hr

**5.0**

**100,000**

**1102**

## After Lighting Retrofit

Lights  
watts/ft<sup>2</sup>

Air Side  
cfm

Latent  
lbs/hr

2.5

62,800

683

## Before Lighting Retrofit

Lights watts/ft <sup>2</sup>	Air Side cfm	Latent lbs/hr
5.0	100,000	1102

## After Lighting Retrofit

Lights watts/ft <sup>2</sup>	Air Side cfm	Latent lbs/hr
2.5	62,800	683

## Before “Controls” Retrofit

Supply Air deg	Air Side cfm	Latent lbs/hr
55 F	62,800	683

## After “Controls” Retrofit

Supply Air deg	Air Side cfm	Latent lbs/hr
60 F	83,733	270

## Before “Controls” Retrofit

Supply Air deg	Air Side cfm	Latent lbs/hr
55 F	62,800	683

## After “Controls” Retrofit

Supply Air deg	Air Side cfm	Latent lbs/hr
60 F	83,733	270

**“Removing only 270 pounds of  
moisture ?.....**

**This spells Trouble !!**

**Trouble !!**

**Trouble !!**

## After “Controls” Retrofit

Supply Air deg	Air Side cfm	Latent lbs/hr
60 F	83,733	270

## The *Right* Solution *Reduce* Supply Air Temperature

Supply Air deg	Air Side cfm	Latent lbs/hr
45 F	38,060	880

# What is the difference

Hmm? What's going on here ?

Current practice vs. distribution

supply air	55 F	45 F
room setpoint	75 F	78 F
delta t	20 F	33 F
cfm/ton sensible	550	335

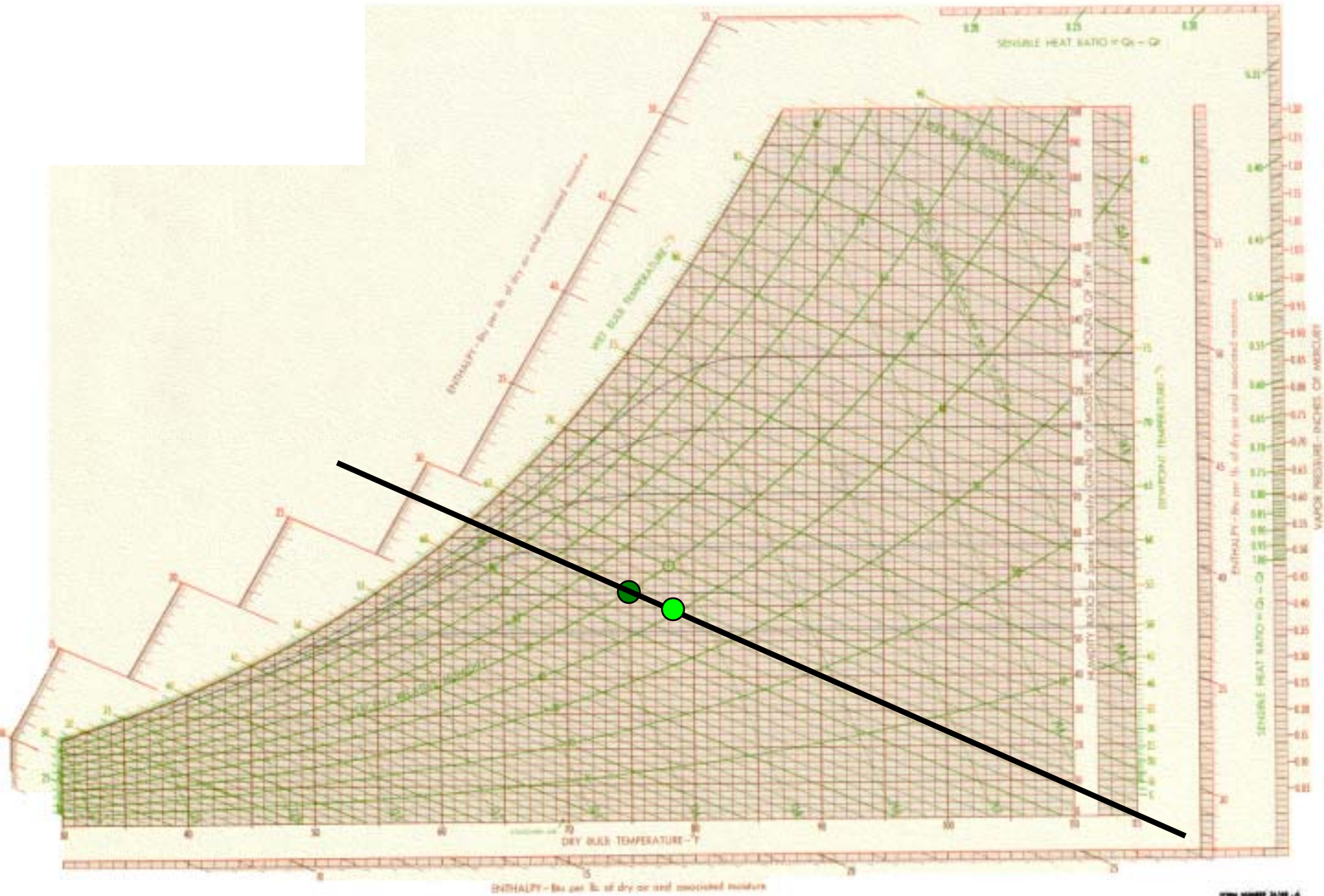

# Cold Air Risks

- ◆ **Engineering Requirements**
- ◆ **Moisture Carryover**
- ◆ **Possible Condensation**
- ◆ **Downdrafts (dumping)**

# Cold Air Risks

- ◆ **Engineering Requirements**

**“Cold air distribution is engineering revitalized.....**

**Rules of thumb no longer apply,  
sound engineering practice does.”**

# Cold Air Risks

- ◆ **Moisture Carryover**

**less cfm / more condensate**

**liquid carryover**

**vapor carryover**

# Liquid carryover

**face velocity blows condensate off the coil**

**coil coatings**

**draw-thru air handlers**

**new fin design**

**face velocity < 500 fpm**

# Vapor carryover

**high coil efficiency causes fog**

**reheat**

**draw-thru air handlers**

**air blenders**

# Cold Air Risks

- ◆ **Downdrafts**

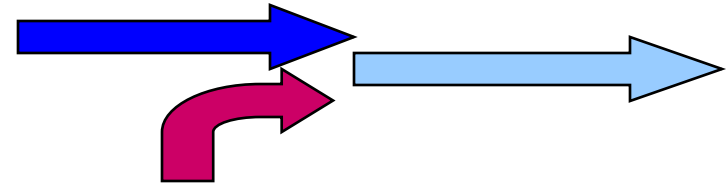

**cold air directly to the space**

**or**

**fan powered units**

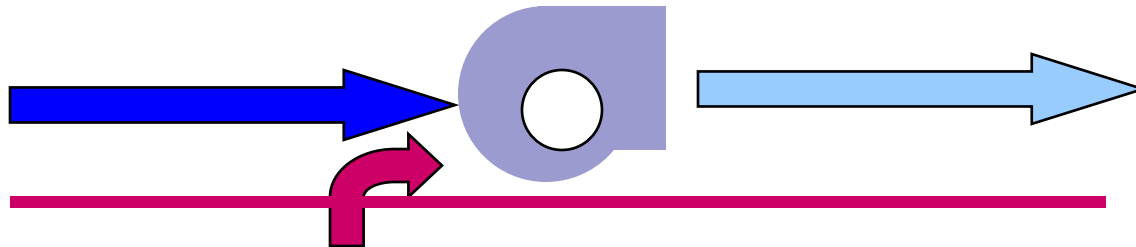

# Cold Air Risks

- ◆ Possible Condensation

thermal ratio =

$$\frac{\text{ambient dew point} - \text{supply air drybulb}}{\text{ambient drybulb} - \text{supply air drybulb}}$$

## Common Practice

75 F space

60% rh

55 F supply air

$$\text{thermal ratio} = \frac{60-55}{80-55} = \frac{5}{25} = \mathbf{0.20}$$

## Common Practice

75 F space

60% rh

55 F supply air

$$\text{thermal ratio} = \frac{60-55}{80-55} = \frac{5}{25} = \mathbf{0.20}$$

## Cold Air Distribution

78 F space

40% rh

45 F supply air

$$\text{thermal ratio} = \frac{52-45}{85-45} = \frac{7}{40} = \mathbf{0.175}$$

# Preventing unwanted condensation

**Positive building pressure control is the  
best defense against IAQ problems...**

**humidity control envelope**



# 5 Ton Rooftop

1600 cfm

1750 cfm

Fan Energy

more

Fan Noise

louder

Relative Humidity

higher

Compressor Energy

higher

Compressor Capacity

higher

Compressor Cycle Rate

faster

Drafts

perceptible

Space Temperature Swings

perceptible

Chance of Coil Frosting

less

# 5 Ton Rooftop

**Is 1750 cfm the right air flow?**

**Is 1600 cfm the wrong air flow?**

**Is 1400 cfm a better air flow?**

**Test, adjust, and balance is the process of bringing equipment into specified performance.**

**Commissioning, or re-commissioning for existing buildings is bringing systems into compliance with the “Design Intent”**

# “Setpoints”

**Don Eppelheimer**  
**The Trane Company**  
**La Crosse, Wisconsin**